

→ **The essence of Line**

Sintesi più alta tra design, tecnologia e funzionalità; Smooth Line è la rivoluzione che introduce il rasomuro nel mondo dei comandi.

→ **The essence of Line**

The highest synthesis between design, technology and functionality; Smooth line is the revolution introducing the idea of flush in the world of controls.

→ **Das Wesentliche von Line**

Smooth Line verbindet Design, Technologie und Funktionalität auf höchstem Niveau und präsentiert das revolutionäre Konzept eines Schalters, welches mit der Wand eine bündige Ebene bildet.



23	Comandi Switches <i>Bedienungsschalter</i>
27	Portelli Closing lid <i>Klappdeckel</i>
31	Prese Sockets <i>Steckdosen</i>
35	Orientamento Signs of orientation <i>Orientierung</i>
37	Smooth Light Smooth Light <i>Smooth Light</i>
39	Videocitofono e Cronotermostato Video intercom & timer-thermostat <i>Videogegensprechanlage und Zeitthermostat</i>
41	Componenti Components <i>Bestandteile</i>
56	Installazione Installation <i>Installation</i>







Eclettis®

➤ La totale complanarità tra placca e parete deriva da una nuova concezione dei componenti di installazione. Il cuore del sistema, coperto da brevetto internazionale, è nella progettazione di nuove scatole e controtelai che creano asole perfette per l'installazione dei componenti. La placca ha un particolare sistema di apertura che elimina qualsiasi elemento di fissaggio a vista ottenendo un'assoluta eleganza.

➤ The complete coplanarity between plate and wall comes out from a new concept of installation components. The heart of the system, covered by international patent, lies in the design of new embedding box and counter frame making the perfect slots for the components installation.

The plate has a particular opening system which removes any fixing element in view, reaching the absolute elegance.

➤ Die absolute Vollendung einer bündigen Oberfläche zwischen Wand und Abdeckplatte ist das Ergebnis eines neuen Konzeptes der Installationsbestandteile. Das Herzstück des international patentierten Systems liegt in der Entwicklung neuer Einbaudosen und Rahmen. Dieses System bietet eine perfekte Lösung für die Installation der einzelnen Bestandteile. Die Abdeckplatte hat ein spezielles Öffnungssystem, das alle sichtbaren Befestigungselemente verdeckt und für höchste Eleganz sorgt.





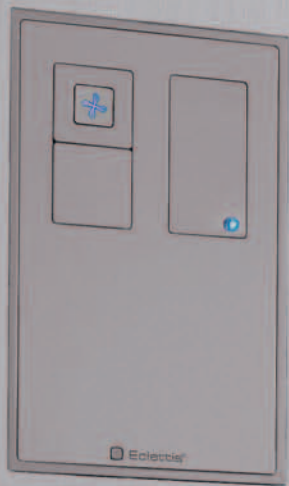



























➤ I comandi elettronici sono multifunzione e programmabili da pulsante, interruttore e deviatore con carichi gestiti direttamente dal contatto. I comandi possono essere personalizzati con icone intercambiabili e retroilluminabili da LED. Scritte e icone sono incise laser con la massima precisione.

La gamma è completata da comandi per impianti domotici, nel rispetto estetico della linea.

➤ The electronic commands are multifunctional and selectable as push button, switch and two way switch in order to control directly the applied loads. They can be personalized by interchangeable icons and backlit. Writings and icons are high precision laser engraved.

The range is completed by home automation controls, in respect of the aesthetic of line.

➤ Die elektronischen Bedienungsschalter sind multifunktional und kompatibel, wodurch die Taster, Umschalter und Wechselschalter mit direkt vom Kontakt angesteuerter Leistung programmierbar sind. Die Schalter können durch austauschbare und hintergrundbeleuchtete LED-Ikonen individuell gestaltet werden. Die Schriftzüge und Ikonen werden mit höchster Genauigkeit mit Hilfe eines Lasers hergestellt. Das breite Angebot wird durch Bedienungsschalter für BUS-Systeme ergänzt, welche die Ästhetik des Smooth Line-Systems weiterführen.



► Fino ad 8 comandi su un'unica placca. La modularità del sistema Smooth Line permette di poter adattare diverse configurazioni su una stessa scatola, completando il sistema con la placca che più si adatta al tipo di soluzione scelta. Un comando, due comandi, quattro comandi, fino ad arrivare alla soluzione richiesta.

► Up to 8 commands on one single plate. The modularity of the Smooth Line allows to adapt several configurations on a same box, and allows to finish the work with a plate which better fits to the solution chosen by our clients. One command, two commands, four commands up to reach the required configuration.

► Bis zu 8 Bedienungsschalter auf einer Abdeckplatte sind möglich. Mit dem Smooth Line-System können verschiedene Konfigurationen auf demselben Gehäuse untergebracht werden. Dabei kann das System mit der für das gewählte Modell am besten geeigneten Abdeckplatte ausgestattet werden. Ein, zwei, oder mehr Bedienungsschalter – wählen Sie Ihre individuelle Konfiguration!



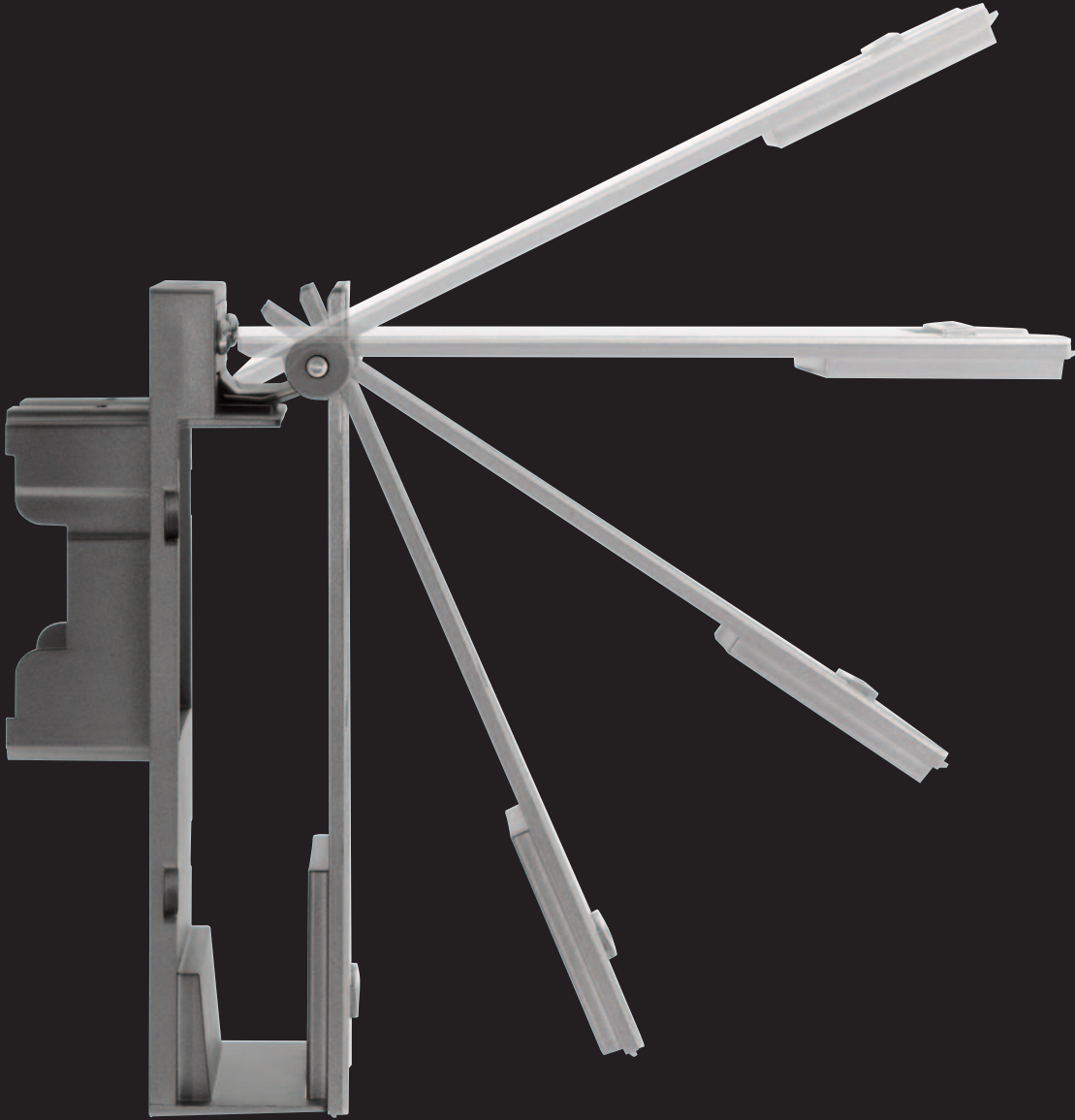

Portelli
Closing lids
Klappdeckel

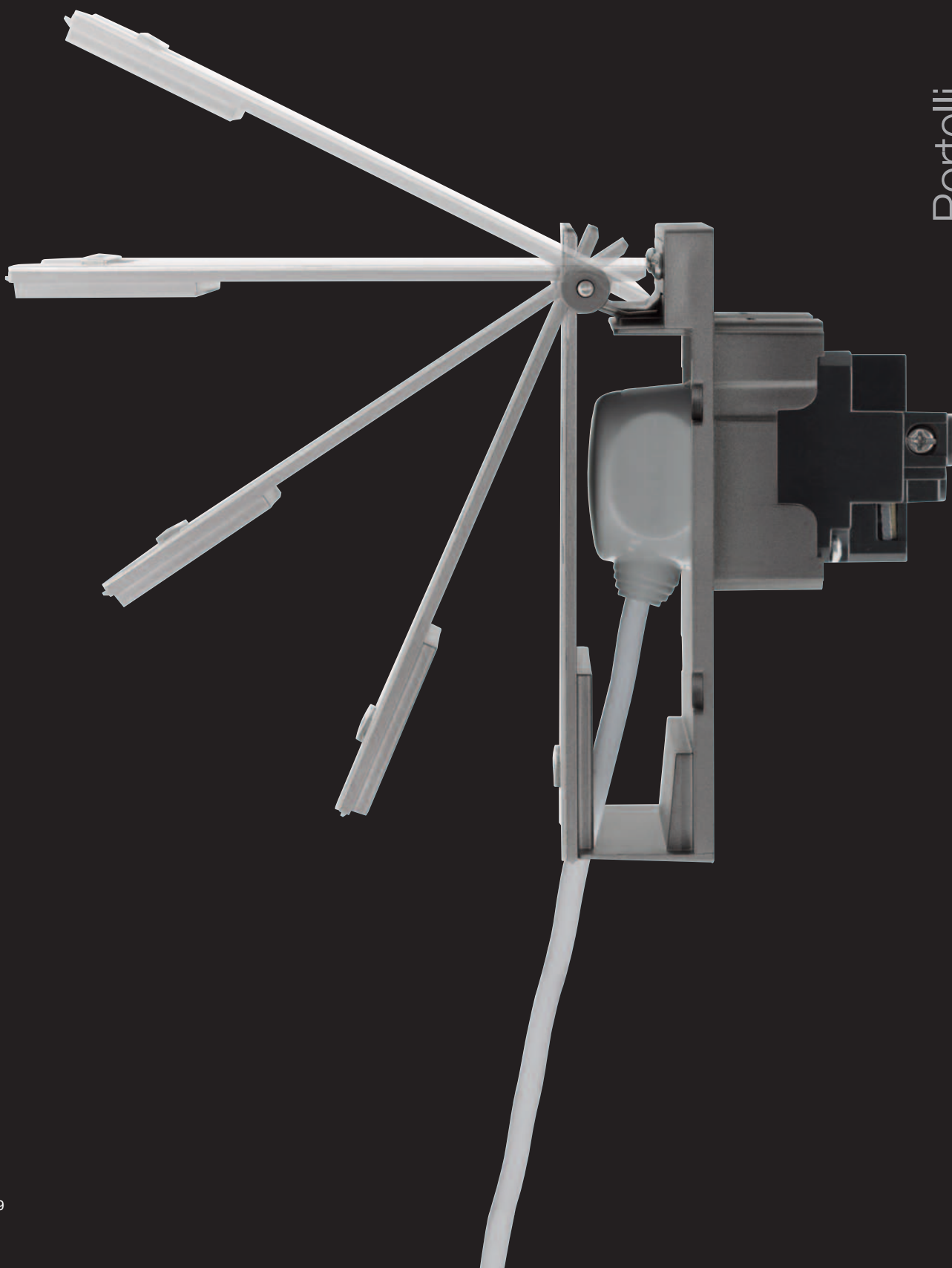



► Eleganza e linearità anche per portelli. I sistemi di chiusura, sempre a filo parete, sono realizzati per avere la presa protetta anche a spina inserita. La gamma dei portelli comprende vari accessori: sistemi con una particolare guarnizione che rende il portello stagno all'acqua anche a spina inserita. La gamma si completa con un portello per gli impianti di aspirazione centralizzati. Stessa estetica, diversa tecnologia.

► Elegance and linearity lie also in the system offering total cover of outlets. This closing system offering total cover of outlets, always flush, is just designed in order to have sockets safe also and especially when the plug is inserted. The range comprehends several accessories: systems with a special gasket making the closing lid watertight when plug is in. The range comprehends also a closing lid covering the vacuum system connection. Same aesthetic but different technology.

► Eleganz und Linearität wird auch bei den Klappdeckeln gewährleistet. Die ebenfalls komplett mit der Wand bündigen Schließsysteme haben die Funktion, die Steckdose auch mit eingefügtem Stecker zu schützen. Das Angebot der Klappdeckel umfasst ein breites Zubehör: Systeme mit spezieller Dichtung, die den Klappdeckel auch bei eingefügtem Stecker wasserdicht macht. Das Angebot wird durch einen Klappdeckel für Zentralabsauganlagen ergänzt. Dieselbe Ästhetik für eine neuartige Technologie.

Portelli
Closing lids
Klappdeckel



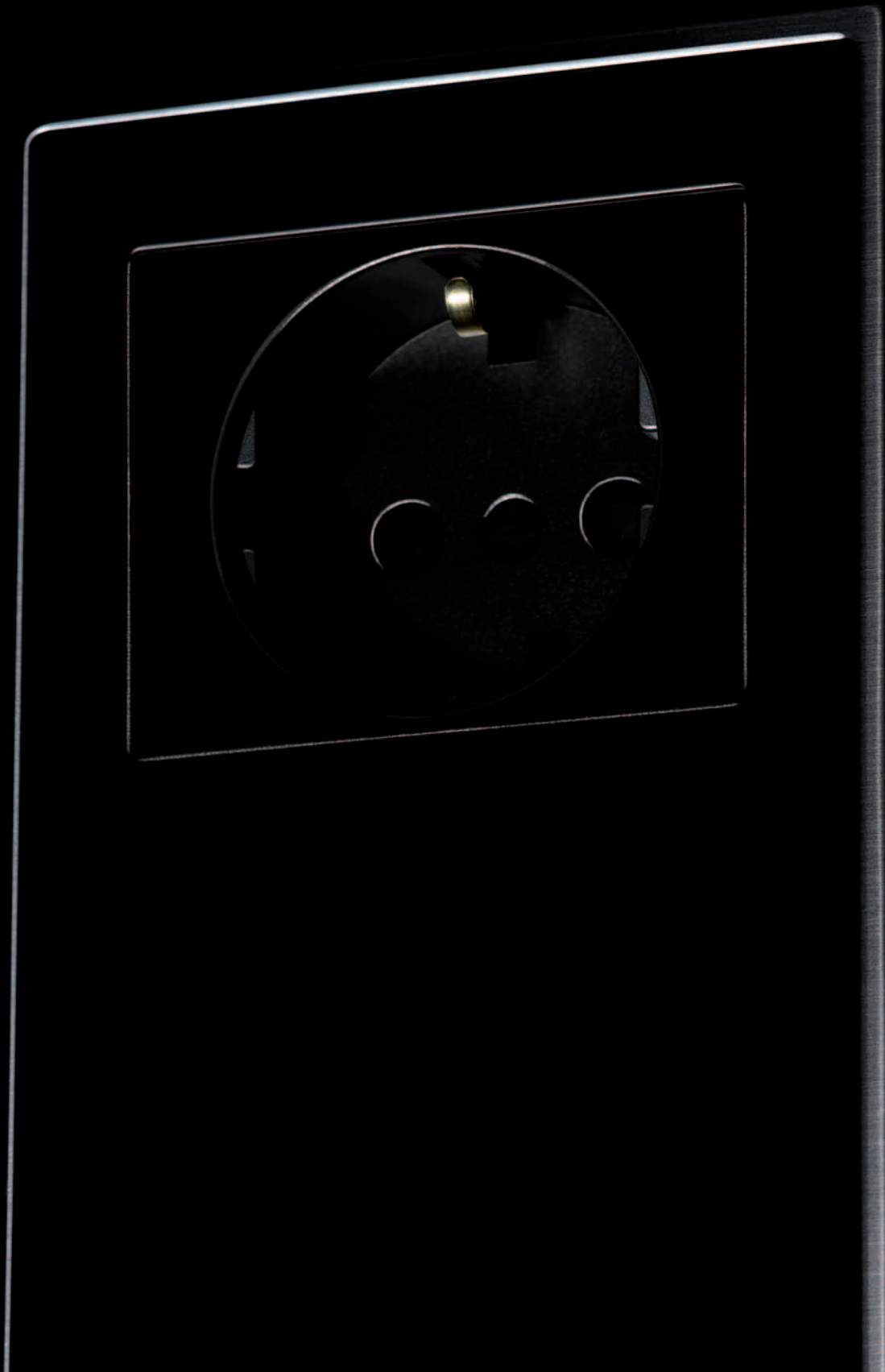

▣ Flessibilità di composizioni per prese elettriche, dati e segnali; anche a filo parete.

▣ Flexibility of compositions for electrical sockets, TV and satellite jacks; also flush with the wall.

▣ Flexibilität bei der Kombination von elektrischen Steckdosen, Datenanschlüssen und Signalen; ebenfalls mit der Wand bündig.

Prese
Sockets
Steckdosen

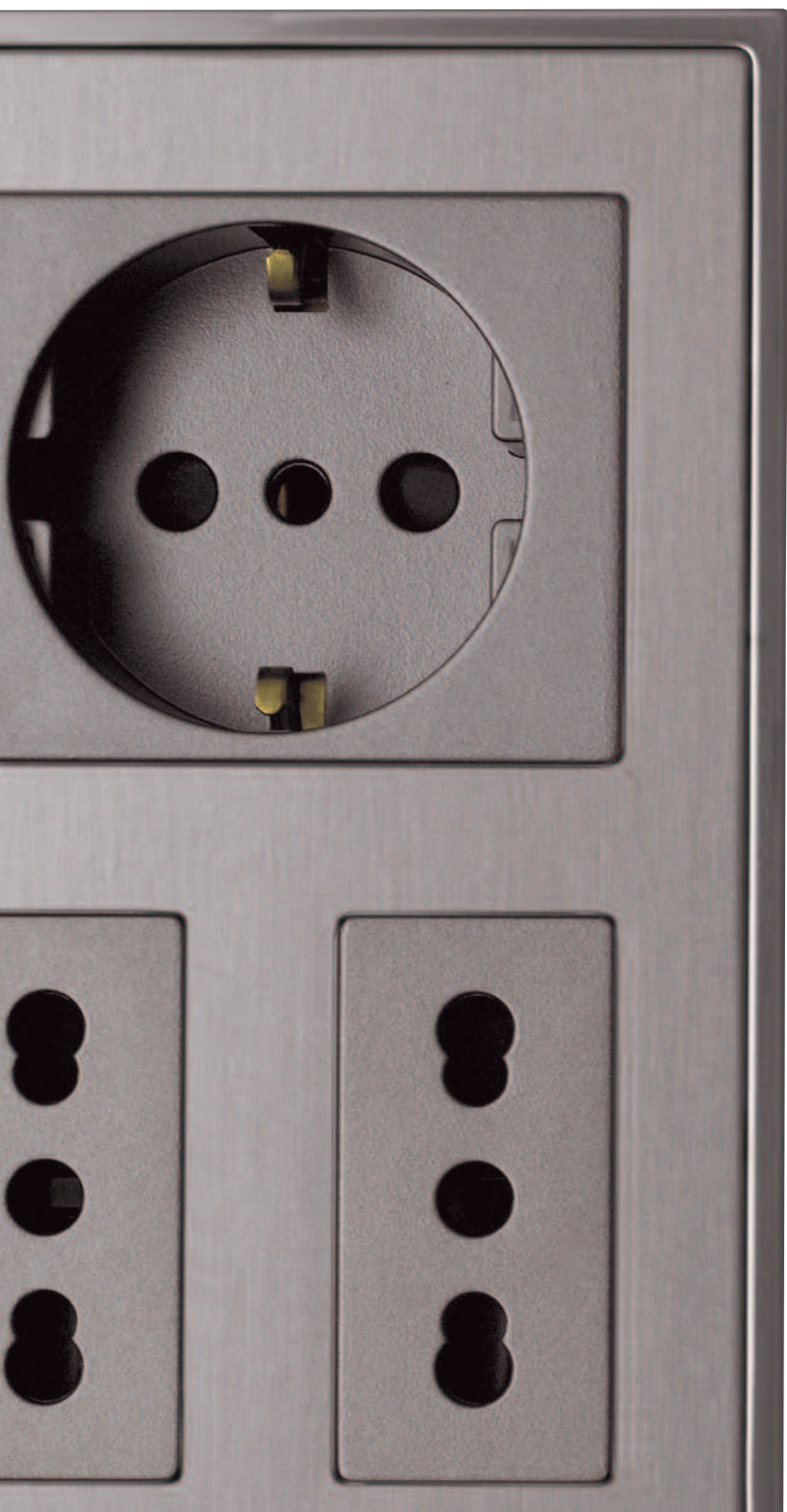

Trattate con una finitura che le rendono omogenee alla placca su cui sono installate, le prese hanno la stessa modularità dei comandi; fino a quattro prese su una unica placca. La gamma comprende anche le prese standard dei vari paesi.

Con l'applicazione di un separatore nella scatola è possibile installare su una stessa placca, prese di potenza e trasmissione dati.

Having the same finishing of the plates which make them homogeneous, sockets have the same modularity of commands; up to four sockets in one plate. The range includes also standard sockets in use in the main countries of the world.

Adding a separator in the box it is possible to install together in a same plate both power sockets, data, TV and satellite jacks.

Die Steckdosen sind wertig verarbeitet und mit der installierten Abdeckplatte homogen. Es können, wie bei den Bedienungsschaltern, bis zu vier Steckdosen auf einer einzigen Abdeckplatte installiert werden. Das Angebot umfasst selbstverständlich auch die Standard-Steckdosen der verschiedenen Länder.

Mit Hilfe von Trennungselementen in der Einbaudose ist es möglich auf derselben Abdeckplatte Kraftstromsteckdosen und Datenübertragungsanschlüsse zu installieren.



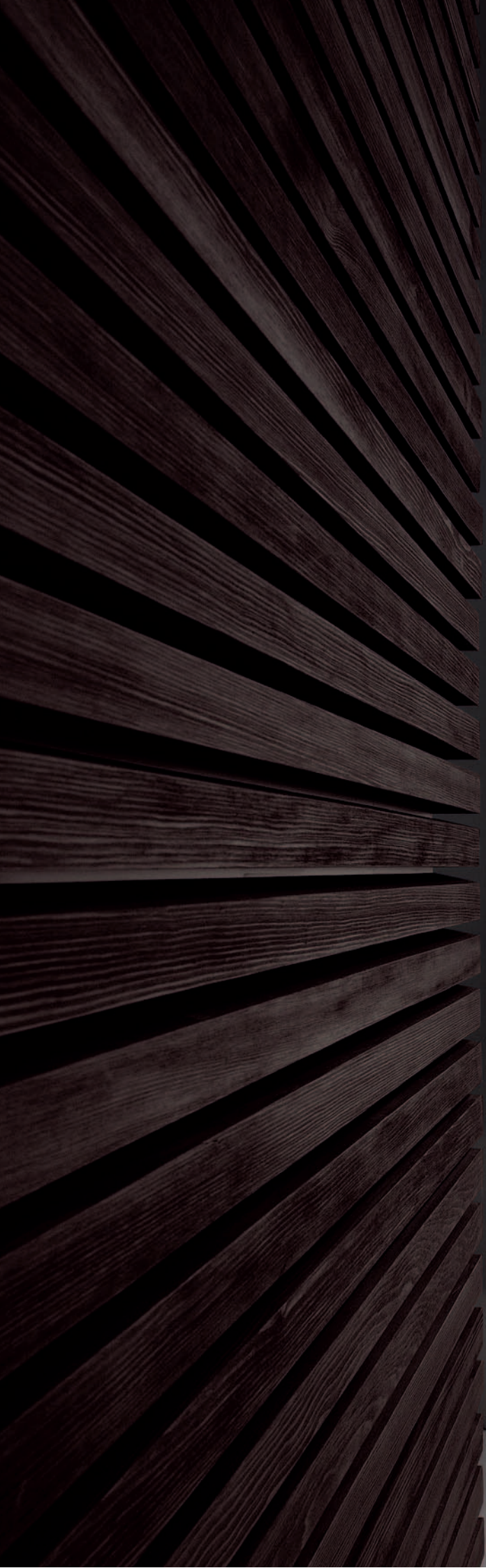

► Le linee e il design della Smooth Line hanno permesso di completare la serie raso muro con segnaletica di orientamento, novità assoluta per il settore.

Led ad alto rendimento e iconografia personalizzata sono le caratteristiche di questa nuova serie di prodotti.

► Smooth line design and shape give the opportunity to complete the flush series through the orientation sign system: an absolute new idea in the sector.

High performance led and personalized icons characterize this new line of products.

► Die Smooth Line-Serie und ihr Design haben es möglich gemacht, die wandbündigen Systeme mit Orientierungszeichen zu ergänzen, welches eine absolute Neuheit im Schaltersektor darstellt.

Kennzeichnung dieser neuen Produktserie sind Hochleistungs-LEDs und individuell gestaltete Ikonen.

Orientamento
Sign of orientation
Orientierung

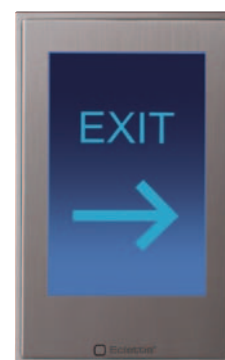



► Tutto è coerente nella gamma Smooth Line. Il nuovo sistema d'illuminazione a filo muro, compatibile con la stessa scatola della serie elettrica, è un ulteriore richiamo alla linearità e al design che contraddistingue l'intera Smooth Line.

► Everything is coherent in the Smooth Line range. The new lighting system, completely flush, is compatible with the same embedding box of the electrical line. One more time it recalls linearity and design which distinguish the whole Smooth Line.

► Bei der Smooth Line-Serie ist alles aus einem Guss. Das neue, mit der Wand bündige Beleuchtungssystem ist mit den Einbaudosen der elektrischen Serie kompatibel. Es stellt eine sich wiederholendes Gesamtbild dar, welches für die gesamte Smooth Line-Serie durch Linearität und ihr Design charakterisiert wird.

Smoothlight
Smoothlight
Smoothlight

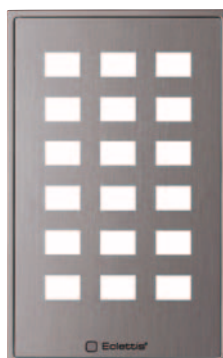



► Niente è lasciato al caso. Cronotermostato, componenti di Citofoni e videocitofoni completano la gamma della Smooth Line. Un ulteriore segno distintivo ottenuto grazie alla collaborazione con importanti aziende del settore.

► Nothing is left to chance. Timer thermostat, intercom and video intercom complete the Smooth Line range.

They represent a further sign of distinction, thanks to a joint work with some important companies of the sector.

► Hier wird nichts dem Zufall überlassen. Zeitthermostat, Bestandteile der Türsprechanlage und Videosprechanlage runden das Smooth Line-Angebot ab. Es stellt, dank der erfolgreichen Zusammenarbeit mit wichtigen Unternehmen in unserem Sektor, ein weiteres Erkennungsmerkmal dar.

Videocitofono e cronotermostato
Video intercom & timer thermostat
Videosprechanlage und Zeitthermostat



